

Large Bore Metric





Committed to sustainable development, Philmac is well renowned for quality products and services. Philmac manufactures pipe fittings and valves under a Quality Assurance System assessed and approved to ISO 9001-2000 and has obtained the prestigious environmental management certification ISO 14000. Philmac has a NATA accredited laboratory and tests fittings and valves to international and national standards. Third party accreditation is carried out by SAI Global.

CONTENTS

Introduction	2
Benefits	2
Standards	3
System Design Considerations	4
Chemical Resistance	5
Installation Instructions – Metric	6
– Threaded Fittings	7
– Flanged Adaptor	8
Principals of Operation	9
Materials & Components	10
Applications	10
Range Dimensions & Weights	11
Product Specifications	16



Large Bore version publish November 2008

Reference Number:TMLB002-1108

Disclaimer

Please note that the information, opinions, recommendations and advice given in this manual are supplied only to provide an improved understanding of the technical aspects of fitting systems.

So far as the law allows, Philmac Pty Ltd will not accept liability in respect of any loss or damage of any kind claimed to arise as a result of reliance upon any information claimed in this manual.

Please refer to our Terms and Conditions of sale.

Philmac's Metric compression fitting revolutionises PE pipe joining technology. Built on Slide & Tighten™ technology, connecting PE pipe has never been faster or easier.

Philmac's unique Slide & Tighten™ technology means that pipe preparation and loose components become a thing of the past. Simply slide the pipe into the fitting and tighten the nut to the flange. It's really that easy.

The Philmac Large Bore Metric compression fitting is made from advanced thermoplastic materials providing a high degree of corrosion and UV resistance. The material is also lightweight and is completely non-toxic and taint free. Rated to 1600kPa and providing a greater than 50 year design life, Philmac's Large Bore Metric compression fitting is designed to handle the most demanding conditions.

Designed to make the job at hand so much easier, the Large Bore Metric fitting is the product of Philmac's unrelenting commitment to continuous improvement and a culture based on innovation and ingenuity.

BENEFITS

Fast and Easy Installation

Slide & Tighten™ technology: Philmac Large Bore Metric incorporates all the benefits of Philmac's Slide & Tighten™ technology. Simply insert the pipe until the first point of resistance is felt, and then tighten the nut up to the flange of the fitting body. No pipe preparation is needed and no force is required to push the pipe past the seal, so installation couldn't be faster or easier. The advantage becomes even more significant in the larger sizes due to the cumbersome nature of large diameter pipes.

Easy Disassembly: The fitting has been designed so that the once the nut is backed off 3 threads, the pipe can easily be removed from the fitting

Complete Security

Dynamic Sealing Method: The mechanical advantage of the nut thread is used to push the seal into a compressed position, eliminating resistance when inserting the pipe into the fitting, so there is no risk of seal distortion or displacement.

Visual stop: The flange on the body of the Philmac Large Bore Metric fitting provides a visual stop to indicate when the nut is fully tightened. This removes any uncertainty from the installation process.

No Loose Components: Although disassembly of the fitting is not required for installation, if the nut is removed there is no danger of losing components as they are all retained within the nut. Losing components in the trench becomes a thing of the past.

Designed to minimize pipe twist: The fitting has been designed to minimize pipe twist as the nut is tightened. Maximum pipe twist is approximately three quarters of a turn compared to one and a half turns with many other fittings. Pipe twist can impact not only on the connection you have just made but also on the connection at the other end of the line.

Approvals: Philmac Large Bore Metric is WSAA and WaterMark approved (Australia) and WRAS (UK).

High Performance Materials

Made from advanced thermoplastic materials: Philmac Large Bore Metric is manufactured from lightweight high performance thermoplastic materials with outstanding impact, UV, chemical and corrosion resistance. The material is non-toxic and taint-free.

Rated to 1600 kPa (16 Bar): Philmac Large Bore Metric is pressure rated to 1600 kPa (16 bar, PN16 or 230 psi) to meet the needs of high pressure systems.

50 year + design life: Built to withstand the toughest conditions to ensure longevity and durability, Philmac Large Bore Metric has a 50 year+ design life.

Complete Coverage

Wide range: The Philmac Large Bore Metric range is comprehensive; straight and reducing joiners, tees, elbows, threaded connectors and end caps ranging from 75 – 110mm.



STANDARDS

Philmac Metric is a complete range of mechanical fittings designed to make connections simple when joining metric PE pipes.

Philmac Metric's innovative and patented design comprises the following product mix;

Product Description	Size (mm)	Maximum Operating Pressure (kPa)
Compression fittings (PE x PE/PI BSP/MI BSP)	75, 90 & 110	1600 (16bar)
Accessories - Spanners - Clips	75-110 75-110 75-110	

Philmac Large Bore range of compression fittings hold certificates for the following standards:

AS/NZS 4129: Fittings for polyethylene (PE) pipes for pressure applications.

AS/NZS 4020: Testing of products for use in contact with drinking water.

BS 6920: Products for use in contact with water intended for human consumption with regards to their effect on the quality of water.

Philmac Large Bore exceeds the requirements of:

ISO 14236: Plastics pipes and fittings -- Mechanical-joint compression fittings for use with polyethylene pressure pipes in water supply systems.

Philmac Large Bore threads and flanges comply with the requirements of the following standards:

AS 1722.1-1975: Pipe threads of Whitworth form - Sealing pipe threads (superseded by ISO7.1)

BS21: Specification for pipe threads for tubes and fittings where pressure-tight joints are made on the threads.

ISO7.1: Pipe threads where pressure joints are made on the threads.

AS 2129 Table E (Drill Pattern): Flanges for pipes, valves and fittings.

Philmac Large Bore fittings are suitable for use with pipes manufactured to the dimensions specified in the following standards:

AS/NZS 4130: Polyethylene pipes (PE) for pressure applications.

BS6730: Specification for black polyethylene pipes up to nominal size 63mm for above ground use for cold potable water.

BS 6572: Specification for blue polyethylene pipes up to nominal size 63mm for below ground use for potable water.

BS EN 12201-2:2003: Plastic piping systems for water supply. Polyethylene (PE). Pipes.

EN 12201: Plastic piping systems for water supply. Polyethylene (PE).

ISO 4427: Plastics piping systems -- Polyethylene (PE) pipes and fittings for water supply.

SYSTEM DESIGN CONSIDERATIONS

There are generally two types of PE pipe fittings; mechanical and thermofusion. Philmac Large Bore Metric is a range of mechanical fittings that offers three distinct advantages over thermofusion fittings;

- **More economical**
- **Quick and easy installation**
- **Quick and easy revision to installation**

This section highlights engineering considerations when designing a PE pipe system with Philmac Large Bore Metric.

Projected life of Compression fittings

Whilst Philmac Large Bore conforms to institutionalised specifications written to have a minimum life of 50 years, its compression fittings are intentionally developed to exceed the expectations of these specifications.

Head Losses

The following table offers a guide in estimating head losses in PE pipe systems based on the conveyance of water. Use the following formula to estimate this head loss;

$$L = F \times D$$

where L = head loss based on
equivalent pipe length (m)

F = fitting constant

D = pipe inner diameter (m)

Fitting	Fitting Constant (F)
90° elbow	30
90° tee - straight through	12
90° tee - side branch	60

Resistance to Impact

Philmac Large Bore polypropylene body and nut has excellent impact properties compared to other plastic materials.

Abrasion Resistance

Philmac Large Bore is suitable for the transportation of abrasive slurries and will withstand normal conditions found in urban, mining, industrial, rural water and waste water systems.

Weathering

Black polypropylene material contains pigments to provide excellent protection against degradation from ultra-violet radiation. However; long term continuous use above ground does require fittings to be protected from direct sunlight.

Electrolytic Corrosion

The metal reinforcing rings on female threads are made from stainless steel (grade 316) and provide long term resistance to corrosion.

Thermal Insulation

Polypropylene has natural thermal insulation of 2000 times over copper and 200 times over steel.

Light Transmission

The Philmac Large Bore fittings do not transmit light, thus protecting the water quality in potable water pipelines from growth of micro organisms.

Effect on Water

Philmac Large Bore does not impart to the water any odour, taste, colour, or any constituents in concentrations that could be injurious to health.

Pressure Rating

Philmac Large Bore fittings are rated for PN16 and have a maximum operating pressure of 16 Bar, 1600kPa or 230 psi.

Pipe Material

Philmac Safelok® fittings maintain their full rating on PE 100 (HDPE), PE 80B (MDPE) and PE 63 (LDPE)

Temperature Derating

Philmac Safelok® performance ratings are for published at 20°C, for higher temperatures apply the same derating to the Philmac Large Bore fittings as applied to the PE pipe.

Chemical Resistance

Fluids other than Water

Many factors can affect the chemical resistance of plastics. Some of these include temperature, pressure, exposure time, continuous or cyclic expose and the type of mechanical stress applied. The fact that certain combinations of chemicals and mechanical load can induce stress cracking in many otherwise chemically resistant materials, both metallic and non-metallic, is of particular significance.

Mixtures of chemicals can result in a performance quite different than that of each individual chemical. Equally vapours and corrosive liquids can often be combinations of chemicals.

Due to the number of parameters that influence the performance of metals and plastics in the presence of chemicals the performance can differ from a laboratory test. Philmac strongly recommends that the final decision be based on the results of a trial installation evaluated under actual service conditions.

Evaluation method

To evaluate the performance of Philmac Large Bore fittings evaluate each of the materials used in the fittings (as listed on Page 8) by using material chemical performance tables.

Normally only the wetted area of the fitting, ie the Body and Seal need evaluation. For immersed applications the Split Ring and Spacer also need evaluation.

Philmac Assistance

To evaluate the performance of a material in the Philmac product in the presence of chemicals please contact Philmac and supply the following five parameters.

Size. What size is the valve and pipework?

Temperature. What temperature will the chemicals be at, is the temperature constant or cycling?

Application. Where and how is the valve being used? Is the chemical on the inside or is the valve immersed in the chemical, ie on the outside of the body rather than the inside?

Media. What chemical is being used? Is it a liquid or gas, is it one chemical or are there combinations? Are there surrounding chemicals or gases in the air?

Pressure. What pressure is being applied to the valve? Does it vary?

Remember the **STAMP** acronym.

Chemical Resistance

Chemical	Satisfactory	Consult Philmac
Ammonium Hydroxide	▲	
Alcohol	▲	
Acetone		▲
Auto Transmission Fluid	▲	
Antifreeze	▲	
Benzene		▲
Butane	▲	
Calcium Salts	▲	
Caustic Soda (40% aqueous)	▲	
Cresol		▲
Citric Acid (10% aqueous)	▲	
Copper Salts	▲	
Ethylene Alcohol	▲	
Ethyl Glycol	▲	
Diesel	▲	
Formic Acid		▲
Gasoline		▲
Hydrochloric Acid		▲
Kerosene		▲
Mineral Oils	▲	
Methane	▲	
Methylene Chloride		▲
Nitric Acid		▲
Petroleum Oils	▲	
Sewerage	▲	
Sodium Cyanide	▲	
Sulphuric Acid		▲
Toluene		▲
Turpentine		▲
Transformer Oil	▲	
Zinc Salt Solution	▲	
Note: Fluid Temperature = 20°C		

INSTALLATION INSTRUCTIONS - METRIC LARGE BORE



1. Cut Pipe Square

Clean the pipe end and ensure it is free from burrs. Chamfering or lubrication of pipe is not required.



2. Ready to Use Position

The fitting is pre-assembled and ready to use, however always ensure that 3 threads are showing before proceeding. Check that fitting body is lubricated - use water or CRC lubricant if required.



3. Witness Mark the Pipe

In the ready to use position lay the pipe against the fitting with the end of the pipe lined up with the flange of the body. Witness mark the section of pipe that is alongside the nut opening.



4. Pipe Insertion

Insert the pipe up to the witness mark, or if not using a witness mark until the first point of resistance is felt.



5. Nut Tightening

The nut should be tightened by hand and then firmly with a wrench. Tighten the nut all the way to the flange on the body of the fitting.



6. Fully Installed

The fitting is now fully installed.

THREADED FITTINGS - INSTALLATION INSTRUCTIONS

Philmac 3G™ Compression fittings offer a range of advantages over metal threaded fittings

- **Faster, Easier and Reliable Installation.**
- **Less Effort through lower friction**
- **Based on over 40 years of experience in Europe and Australia**
- **Exploits the properties of Polypropylene to reduce the installation effort compared to metal threads**

Based on over 40 years experience

Philmac manufactured the world's first all-plastic compression fitting in 1968. With over 40 years experience you can trust Philmac 3G™ to perform.

Manufactured from Engineering Plastics

Philmac threaded fitting bodies are manufactured from high performance engineering plastics which delivers significant benefits.

Less Friction

Philmac threaded fittings require significantly less effort to install. Delivered through the use of high performance plastic that provide far less friction than metal on metal threads.

New Approach to Installation

Philmac 3G™ fittings usher in a new era of thread connection. The high performance materials conform to slight irregularities in metal threads, whereas metal to metal joints tend to bind increasing the installation effort.

Smaller Lighter tools

A simple set of multi-grip pliers can be used to install a Philmac threaded fitting. Gone are the days when you need a large wrench to install and tighten a threaded fitting.

Proven Performance

Philmac threaded fittings are built tough and are used world-wide by water companies, plumbers and in rural applications.

Example - Male Adapter into a metal valve



1. Apply PTFE tape or suitable* sealant to the plastic thread ensuring sufficient is applied to ensure a watertight seal.



2. Using your hands, screw the thread of the Male Adapter into the valve until firm.



3. Grip the body of the 3G fitting with Multi-grips or similar plumbing tools and continue to screw the Male Adapter into the valve until tight.

Stop if the shoulder of the 3G™ fittings touches the other fitting..

* **Note:** Philmac recommends the use of PTFE tape on threads to ensure a positive seal. If a liquid or paste sealant is used ensure it is suitable to be used with both Polypropylene and the material being connected to the Philmac fitting.

INSTALLATION INSTRUCTIONS - FLANGES



1. Ensure a gasket is used between the flange of the Safelok fitting and the flange to which it is to be connected.



2. Fit the correct size and length bolts to each hole in the flange and hand tighten them.



3. Tighten the bolts with a spanner ensuring the bolts are torqued up correctly in an appropriate sequence, refer Figure 1.

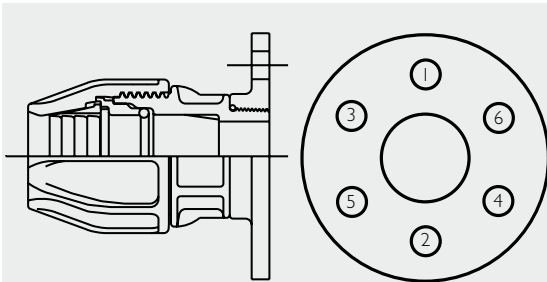

FIGURE 1

Note:

When assembling a flanged adaptor, position the gasket and loosely assemble the fitting. Tighten bolts gradually in sequence shown numerically in Figure 1, to ensure even compression around the flange. Ensure washers are used under bolt heads and nuts.

GENERAL INSTALLATION NOTES

1. Always ensure Philmac fittings are stored away from dusty areas to avoid dust settling on the lubricated seal.
2. Philmac recommends the use of PTFE tape on threads to ensure a positive seal.
3. Philmac Large Bore includes ergonomically designed spanners for fittings.

PRINCIPALS OF OPERATION – PHILMAC LARGE BORE METRIC COMPRESSION FITTINGS

FULLY OPEN

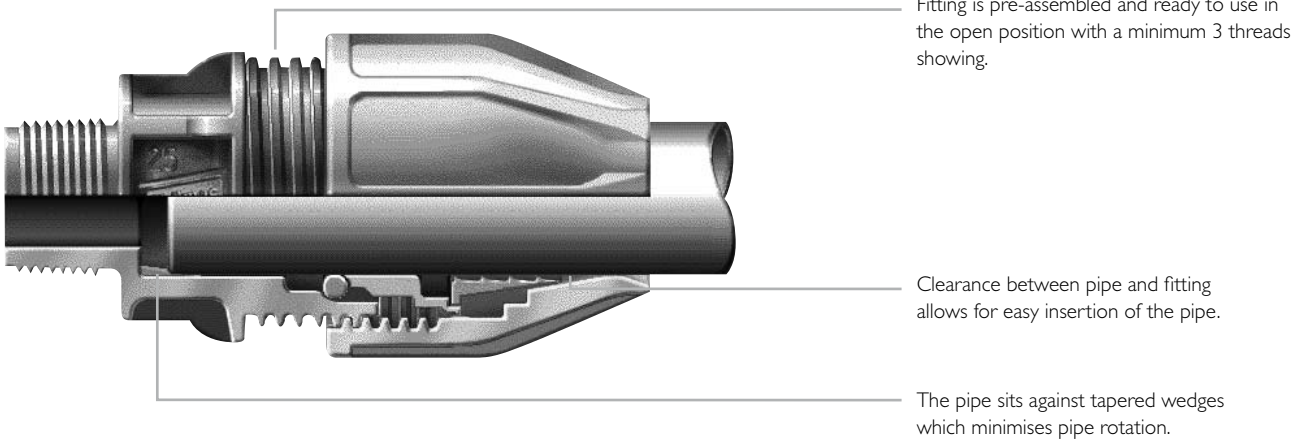

FULLY CLOSED

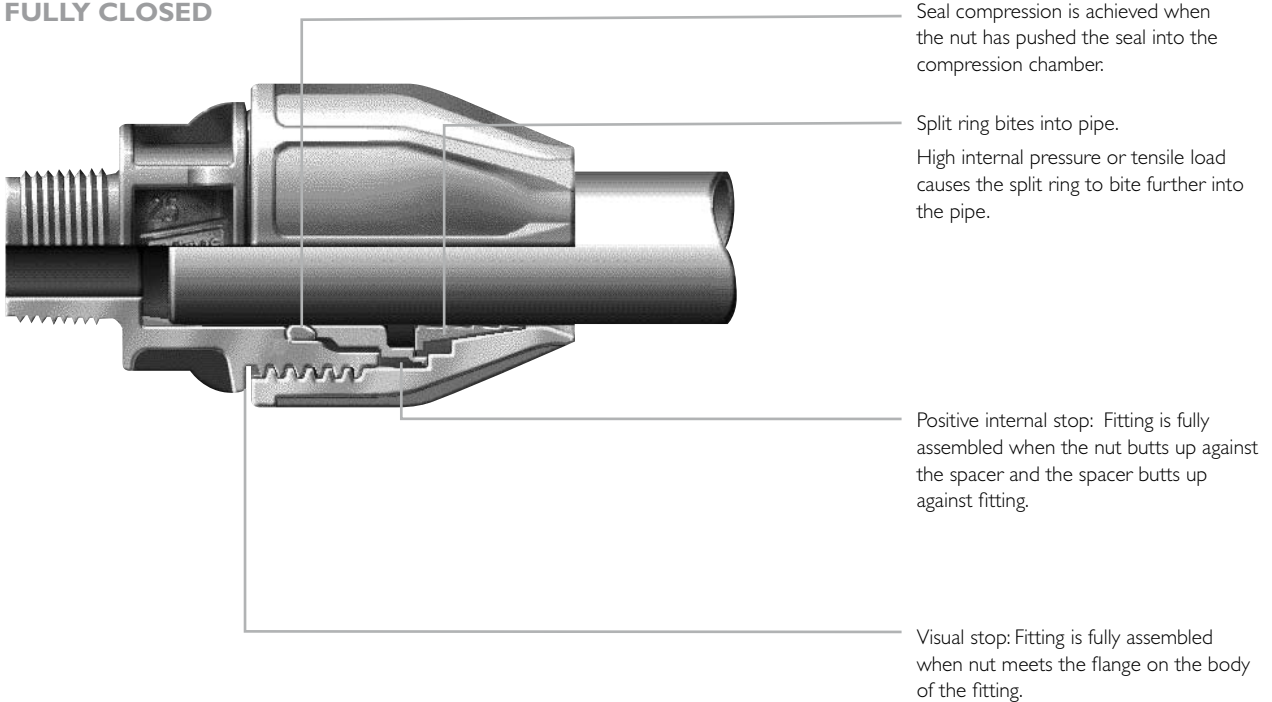

MATERIALS & COMPONENTS

COMPRESSION FITTINGS

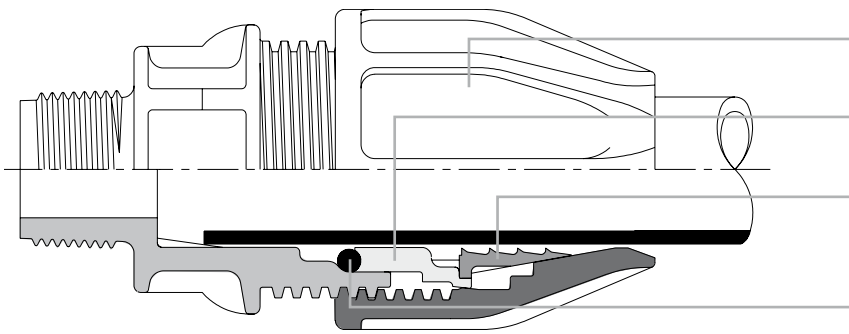

BODY & NUT – Polypropylene

SPACER – Nylon

SPLIT RING – Acetal

SEAL – Nitrile Rubber

LUBRICANT – Silicone oil

FLANGE

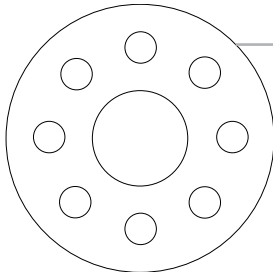

FLANGE – epoxy coated steel

ACCESSORIES

Spanner

Blue powder coated, aluminium.

Clip

Black, polypropylene (PP).

APPLICATIONS

Polyethylene Pipe (PE) is an extremely versatile material which is used for a number of applications. Accordingly, Philmac Metric provides the optimal means of connecting to PE pipes.

Philmac Metric is designed to serve a vast number of industries. The following are only some examples of its uses.

Mining

Conveyance of water, compressed air, chemical solutions and slurries in mines and processing plants.

Plumbing

House connections.

Municipal Water Supply

Water treatment plants and mains-to-meter lines.

Landfill

Conveyance of gaseous fuels

Agriculture/Horticulture/Turf

Mains pressure irrigation systems, golf course irrigation and pump manifolds.

Manufacturing

Conveyance of compressed air, water and chemical solutions.

RANGE DIMENSIONS & WEIGHTS



RANGE DIMENSIONS & WEIGHTS

JOINERS/COUPLING (Pol x Pol)

Size (OD)	Ref No	Dimensions mm.			kg.
		S	D	L	Wt
75mm x 75mm	97 7188 00	43	134	295	1.24
90mm x 90mm	97 7199 00	50	157	350	2.06
110mm x 110mm	97 7100 00	62	190	430	3.61

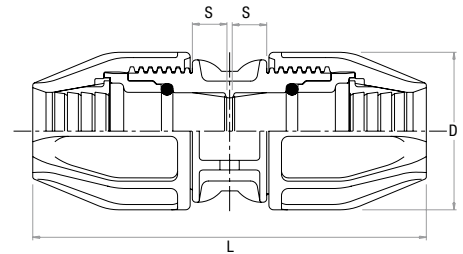

REDUCING JOINERS/COUPLING (Pol x Pol)

Size (OD)	Ref No	Dimensions mm.					kg.
		S	S1	D	D1	L	Wt
75mm x 63mm	97 7187 00	43	24	134	113	274	1.09
90mm x 75mm	97 7198 00	50	43	157	134	322	1.71
110mm x 90mm	97 7109 00	62	50	190	157	393	3.26

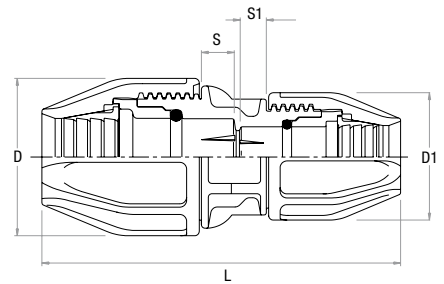

END CONNECTORS (Pol x MI BSP)

Size (OD x BSP)	Ref No	Dimensions mm.				kg.
		S	D	L	T	Wt
75mm x 2"	97 7286 00	43	137	185	31	0.72
75mm x 3"	97 7288 00	43	134	190.5	36.5	0.74
90mm x 3"	97 7298 00	50	157	221	36.5	1.22
110mm x 4"	97 7209 00	62	190	269	43	2.2

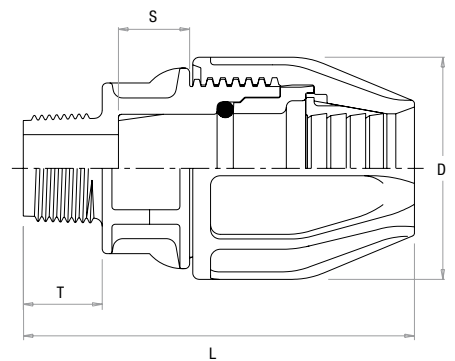

END CONNECTORS (Pol x FI BSP)

Size (OD x BSP)	Ref No	Dimensions mm.				kg.
		S	D	L	T	Wt
75mm x 2"	97 7886 00	43	134	185	34.5	0.75
90mm x 3"	97 7898 00	50	157	219	39	1.26
110mm x 4"	97 7809 00	62	190	267	46	2.20

Stainless steel reinforcing ring on FI Outlets

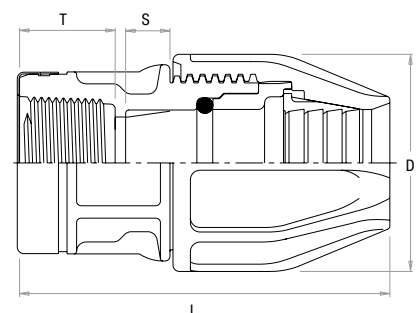

For advice on chemical resistance properties please refer to page 5 and contact your nearest Philmac representative

RANGE DIMENSIONS & WEIGHTS

EQUAL TEES (Pol x Pol x Pol)

Size (OD)	Ref No	Dimensions mm.					kg.
		S	D	H	G	L	Wt
75mm x 75mm x 75mm	97 7388 00	43	134	188	88	375	2.20
90mm x 90mm x 90mm	97 7399 00	50	157	226	100	451	3.63
110mm x 110mm x 110mm	97 7300 00	62	190	276	120	551	6.00

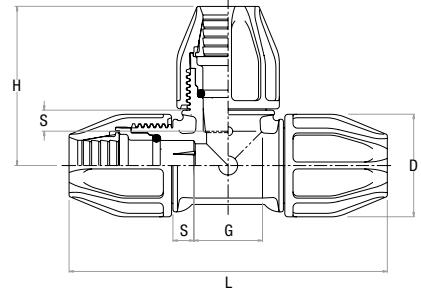

TEES (Pol x FI BSP)

Size (OD x BSP)	Ref No	Dimensions mm.						kg.
		S	D	G	H	L	T	Wt
75mm x 2"	97 7486 00	43	134	88	109	375	34.5	2.24
90mm x 3"	97 7498 00	50	154	100	123	451	39	3.63
110mm x 4"	97 7409 00	62	190	120	150	551	46	6.07

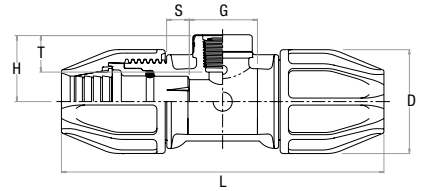

Stainless steel reinforcing ring on FI Outlets

ELBOWS (Pol x Pol 90°)

Size (OD)	Ref No	Dimensions mm.			kg.
		S	D	L	Wt
75mm x 75mm	97 7588 00	43	134	192	1.47
90mm x 90mm	97 7599 00	50	157	233	2.44
110mm x 110mm	97 7500 00	62	190	275	4.29

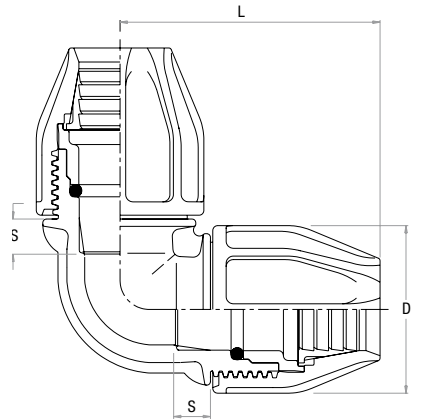

ELBOWS (Pol x FI BSP)

Size (OD x BSP)	Ref No	Dimensions mm.					kg.
		S	D	H	L	T	Wt
75mm x 2"	97 7686 00	43	134	109	189	34.5	1.47
90mm x 3"	97 7698 00	50	157	122	223	39	2.44
110mm x 4"	97 7609 00	62	190	145	273	46	4.29

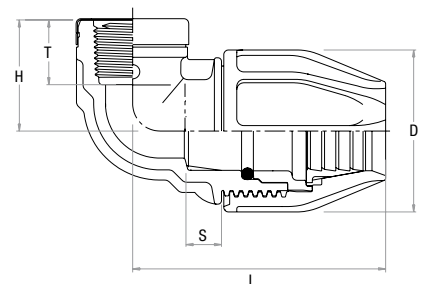

Stainless steel reinforcing ring on FI Outlets

For advice on chemical resistance properties please refer to page 5 and contact your nearest Philmac representative

RANGE DIMENSIONS & WEIGHTS

END CAPS (Pol)

Size (OD)	Ref No	Dimensions mm.			kg.
		S	D	L	Wt
75mm	97 7089 00	48	134	170	0.71
90mm	97 7099 00	55	157	220	1.14
110mm	97 7009 00	67	190	250	1.81

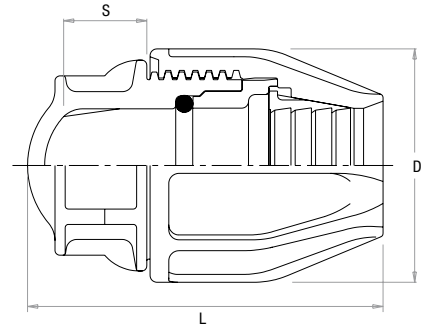

SHOULDERED ADAPTOR

Size (OD)	Ref No	Dimensions mm.			kg.
		A	B	Wt	
50mm x 2"	97 716620	96	165	0.34	
63mm x 2"	97 717620	113	178	0.52	
90mm x 4"	97 719910	157	235	1.34	
110mm x 4"	97 710910	190	282	2.15	

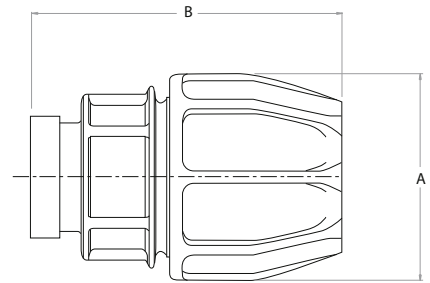

FLANGED ADAPTORS (Pol x Flange)

Size (OD)	Ref No	D	L	Wt (Kg)
50 x 2"	97 7766 XX			
63 x 2"	97 7776 XX			
75 x 2"	97 7786 XX			
75 x 3"	97 7788 XX			
90 x 3"	97 7798 XX			
110 x 4"	97 7709 XX			

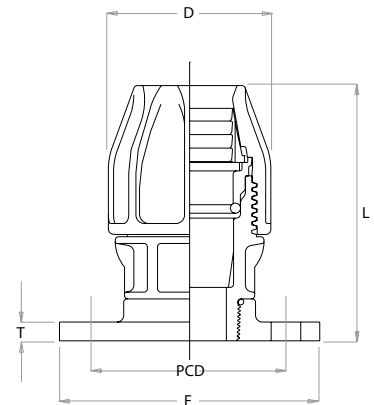

Flange Pattern Codes

Flange Pattern (XX)	Flange Pattern	Flange Coating	PCD	# Holes	Hole Diam	F	T
00	AS2129 Table E	Epoxy					
01	AS2129 Table F	Epoxy					
02	AS2129 Table C	Epoxy					
03	AS2129 Table H	Epoxy					
10	ANSI 150 Flat Face	Epoxy					
11	ANSI 300 Flat Face	Epoxy					
12	ANSI 600 Flat Face	Epoxy					
13	ANSI 150 Raised Face	Epoxy					
14	ANSI 300 Raised Face	Epoxy					
15	ANSI 600 Raised Face	Epoxy					
20	ISO2084/BS4504 NP16	Galvanised					
21	ISO2084/BS4504 NP25	Galvanised					
22	BS 4502 Table II	Galvanised					
30	SABS	Epoxy					

Maximum operating pressure is 1600kPa.

RANGE DIMENSIONS & WEIGHTS

METRIC CHEMICAL RESISTANT KITS

VITON O-Ring with POLYPROPYLENE SPACER - Standard Spacer and O'Ring - NBR Rubber O'Ring and Nylon Spacer

Size (OD)	Ref No
50mm	90 7066 10
63mm	90 7077 10
75mm	90 7088 10
90mm	90 7099 10
110mm	90 7000 10

EPDM O-RING with POLYPROPYLENE SPACER - Standard Spacer and O'Ring - NBR Rubber O'Ring and Nylon Spacer

Size (OD)	Ref No
50mm	90 7166 24
63mm	90 7177 24
75mm	90 7188 24
90mm	90 7199 24
110mm	90 7100 24

POLYSULFONE SPLIT RING - Standard Split Ring - Acetal

Size (OD)	Ref No
50mm	90 7166 26
63mm	90 7177 26
75mm	90 7188 26
90mm	90 7199 26
110mm	90 7100 26

NUT ASSEMBLY KIT - EPDM O-Ring, Polypropylene Spacer, Polysulfone Split Ring and Polypropylene Nut (For submerged applications)

Standard Nut Assembly - NBR Rubber O'Ring, Nylon Spacer, Acetal Split Ring and Polypropylene Nut

Size (OD)	Ref No
50mm	90 7166 10
63mm	90 7177 10
75mm	90 7188 10
90mm	90 7199 10
110mm	90 7100 10

For advice on chemical resistance properties please refer to page 5 and contact your nearest Philmac representative

RANGE DIMENSIONS & WEIGHTS

SPANNERS

Size (OD)	Ref No	Dimensions mm.		kg.
		L		Wt
50 - 110mm	90 7060 00	460		0.35

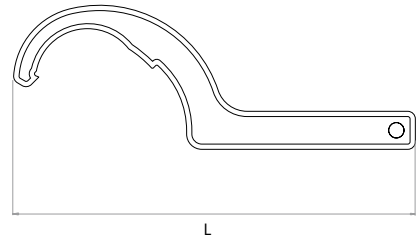

PIPE CLIPS (Bolts/Screws not included)

Size (OD)	Ref No	Bolt size	Dimensions mm.				kg.
			A	B	C	G	Wt
75mm	13 4343 12	M8	122	70	70	31	.094
90mm	13 4343 13	M8	148	80	90	31	.121
110mm	13 4343 14	M8	171	90	96	35	.085

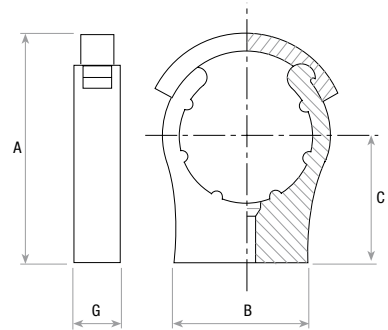

PRODUCT SPECIFICATION

FITTINGS FOR PE TO PE PIPE CONNECTION

Guidelines for the specifications of Philmac Large Bore Metric compression fittings.

Manufacturer Accreditation

Only fittings manufactured by Manufacturers with a Quality System approved to ISO9001 or equivalent shall be accepted for use.

Product Performance Accreditation

Fittings for Polyethylene (PE) pipes shall meet the applicable performance requirements of ISO 14236 with specific reference to:

- a) Pressure Testing (ISO 3458)
- b) External Pressure resistance testing (ISO 3459)
- c) Resistance to pull out of test assemblies at 20 degrees C (ISO 3501)
- d) Internal pressure resistance when subjected to bending stresses (ISO 3503)

Threaded ends of fittings shall be tapered and conform to ISO7.1 (specification for pipe threads for tubes and fittings where pressure tight joints are made on threads).

Product Material Accreditation

Fittings for Polyethylene (PE) pipes shall have a body made from materials tested in accordance with ISO 9080 (Plastic piping and ducting systems – determination of the long term hydrostatic strength of thermoplastic materials in pipe form by extrapolation).

Performance verification shall be according to test parameters outlined in Clause 8.3.2.2 of ISO 14236 – Verification of long term behaviour.

Fittings shall be suitable for the conveyance of drinking water and shall conform to BS6920 and AS4020 (suitability of non metallic products for use in contact with water intended for human consumption with regard to their effect on the quality of water).

Product Configuration/ Material Overview

Fittings shall be of the compression fitting type.

Fitting bodies and nuts shall be of polypropylene material, the spacer shall be of nylon material and the split ring shall be in acetal material. Each fitting shall be supplied complete and pre assembled with captivated split ring, spacer and seal inside the nut.

Seal rings shall be made from nitrile rubber.

Fitting body colour shall be black so as to minimise potential light transmission and/or UV degradation.

Method of Connection

The seal of a joint will be achieved by nut tightening so as to obtain watertightness by a seal ring around the external diameter of the pipe.

Any pipe preparation will be limited to cutting and cleaning of pipe (for foreign material or burrs). Fittings shall not require the pipe to be lubricated or chamfered during installation.

There shall be no loose components during assembly or disassembly (meaning that the fitting shall not be required to be dismantled during assembly or disassembly and if the nut is removed accidentally components will not fall out of the fitting unless removed deliberately).

Philmac Sales

AUSTRALIA

53-59 Deeds Road
North Plympton
South Australia
AUSTRALIA 5037

Telephone 1800 755 899 (within Australia)
Facsimile 1800 244 688 (within Australia)
Email sales@philmac.com.au
Web www.philmac.com.au

NEW ZEALAND, ASIA PACIFIC, SE ASIA, JAPAN, SOUTH AMERICA & OTHER AREAS

53-59 Deeds Road
North Plympton
South Australia
AUSTRALIA 5037
Telephone +61 8 8300 9217

Facsimile +61 8 8300 9390
Email export@philmac.com.au
Web www.philmac.com.au

UNITED KINGDOM, IRELAND, EUROPE, MIDDLE EAST & AFRICA

Diplocks Way
Hailsham
East Sussex
UNITED KINGDOM BN27 3JF

Telephone +44 1323 847 323
Facsimile +44 1323 844 775
Email sales@philmac.co.uk
Web www.philmac.co.uk

NORTH & CENTRAL AMERICA

PO Box 290995
Phelan
California
USA 92329

Cell +1 (760) 217 4075
Facsimile +1 (760) 868 0470
Email export@philmacinc.com
Web www.philmacinc.com

Philmac UK is a trade name of
Glynwed Pipe Systems Ltd.
Company number 1698059.

Registered Office:
Walsall Road
Norton Canes
Cannock
Staffordshire
WS11 9NS
UNITED KINGDOM