

## DURAPIPE GUARDIAN

Durapipe Guardian is a completely new Dual Contained pipework system made from PVC-U material.

Guardian is a unique system that incorporates a patented Centra-Lok™ system, which provides a solid fixed fitting, offering a true point of difference from other dual contained systems on the market.

Manufactured in PVC-U material, Durapipe Guardian is ideal for water and waste treatment applications as it allows the safe transportation of different fluids and some chemical concentrates without fear of corrosion and environmental pollution.

### Key Product Information

- Size Range: ½"#2" up to 8"#12"
- Pressure Rating: Class E 15 bar
- Temperature Rating: +5 to +60°C

### Key Product Features

- Patented Centra-Lok™ system holds fitting in the correct place prior to installation
- Extremely easy to install - Solvent Weld jointing for both inner and outer
- Visual or automated leak detection system available

### Typical Applications

- Water and waste water treatment
- Chemical process
- Pharmaceutical
- Industrial process
- Food and beverage
- Marine
- Potable water



# Guardian

## Guardian Introduction

Dual contained pipework for when leaks are not an option...

### Durapipe Guardian – Your dual contained specialist

Certain environments demand a fail-safe pipework system. *No leaks, no risk.*

For example, safety and environmental control are of great importance in many industrial locations, with the reduction of emissions and energy conservation high on the agenda. With this in mind, many water treatment, chemical waste or process applications are now demanding the extra reliability of a dual contained pipework system.

Durapipe Guardian utilises state-of-the-art technology to use pre-assembled components that guarantee reliability, ease of installation and fewer joints to provide the perfect solution where a dual contained pipework system is required.



## What is Guardian?

### Overview

- Dual contained pipework system
- Full range of pipe, fittings, valves and terminations
- Easy to install
- Fully imperial sized system

### Material Selection

Durapipe Guardian is manufactured from PVC-U material which makes the system ideal for conveying industrial fluids in demanding environments.

### Design

The Guardian system offers a complete selection of pretested modular components which are extremely easy to install.

Our Centra-Lok™ patented design means the Guardian system averages up to 60% fewer overall joints and up to 10% fewer field joints than other systems on the market. Since joints are always the most common source of premature failures and leaks, it is easy to realise the immense impact the patented Centra-Lok™ design has on maintenance, repair and installation costs.

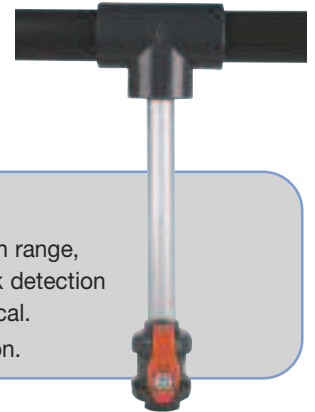

### Leak Detection

As part of the Durapipe Guardian range, we can also offer a range of leak detection systems, both physical and optical. See Page 85 for more information.

### Easy to install

Guardian is the easiest system of its kind (dual contained) to install. Following the same simple solvent cement jointing process as single-wall PVC-U, there are no special tools, equipment or hot works permits required. Please see page 80 for full jointing instructions.



### Where is Guardian used?

- Water and Waste Treatment
- Chemical Waste
- Process Applications
- Chemical Manufacturing/ Pharmaceutical
- Electronics/Data Storage

### What is it commonly used for?

- Chemical Treatment
- Unknown/Hazardous Waste
- Aggressive Chemicals
- High Value Contents
- Water Damage Prevention



## Guardian Installation

### Solvent Cementing (Individual)

#### PVC

1. The pipe must be cut clean and square. A suitable wheel cutter will eliminate swarf. As an alternative (and on larger sizes) a carpenter's saw should be used, however this may create dust and swarf which can enter the system. Remove all burrs from both the inside and outside edge of the pipe with a knife, file or reamer and chamfer the end of the pipe using a coarse file or suitable chamfering tool. The chamfer should be approximately 45° by 3mm to 5mm depending on the pipe size. Remove any dirt, grease or moisture. A thorough wipe with a clean, dry rag is usually sufficient. Check dry fit. Pipe should insert easily into socket, approximately 1/4 to 3/4 of the total socket depth.



2. Clean surfaces thoroughly with Durapipe Eco-cleaner using lint free cloth/paper towel.



3. Using a clean brush, apply Durapipe PVC One-step cement to the carrier pipe and inner fitting. HCR-36 cement and cleaner should be used for aggressive chemicals, for more information please see page 18.

The joint surfaces should be completely covered by cement. Cement should be applied using an appropriate size brush and tin of cement. It is important to apply cement quickly to enable assembly without excessive force being required. When applying cement with a brush, the size of the brush should be approximately half the size of the pipe to be jointed - brush size up to 2 1/2" for 0.5 litre and up to 3" for 1 litre tins.

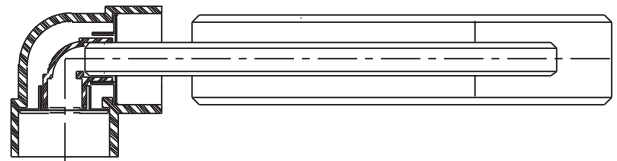

4. Without delay assemble while cement is still wet, push the pipe fully home into the fitting using sufficient force to ensure that pipe bottoms in socket. Hold together for about thirty seconds to make sure joint does not separate. With a rag, wipe off excess cement. Avoid disturbing the joint.



5. Repeat step 3, but this time for the containment pipe and outer fittings.



Without delay assemble the outer joint as described in 4. This process (points 3-6), can be repeated using standard PVC sockets to extend the pipe lengths, until there is a change of direction needed.



### Solvent Cementing (Simultaneous)

There will be circumstances where it will not be possible to joint the carrier pipework and the containment pipework separately. At this point a simultaneous joint will be required.

- 7a. Determine proper carrier pipe lengths to achieve desired centre-to-centre dimension. Cut to size and prep ends as detailed in steps 1 & 2.



- 7b. The containment pipe needs to be shorter than the carrier pipe. This distance can be worked out from the data on pages 83-84.  $A2 - A1 =$  Additional length of carrier pipe eg. for 1/2" # 2" this equates to  $35.1 - 12.7 = 22.4\text{mm}$

Hence the carrier pipe needs to be 22.4mm longer than the containment pipe, for simultaneous jointing. Measure and cut both the carrier and containment pipes to the required distance and chamfer and clean the pipe and fittings as described in steps 1 & 2.



8. Install Centra-guide support at pipe's end. Distance between the fitting and support should not exceed 1 1/2 metres. Install additional supports if required.
9. Clean surfaces thoroughly with Durapipe Eco-cleaner and apply solvent cement to carrier and containment sockets and pipe ends. Push the fitting fully home so that it is against the pipe stop.



10. Wipe off excess cement from the outside of the joint.
11. Do not disturb the joint for at least 15 minutes. On larger sizes do not subject the joint to bending or twisting forces for at least 4 hours. When making subsequent joints, which can be done without waiting, take care not to transmit forces to freshly made joints in the system.

## Termination Fittings

Guardian PVC termination fittings are supplied as one-piece components, complete with carrier pipe O-Rings. Always bevel carrier pipe end or damage to the O-Rings will occur. Clean surfaces of both the containment pipe and socket of termination fitting thoroughly with Durapipe Eco-cleaner. Apply cement to both containment pipe and termination socket and slide into position. Allow 24 hours cure time prior to testing. The fitting is supplied as standard with taps to allow for venting, draining, etc.

**Do not apply Eco-cleaner or solvent cement to O-Rings.**

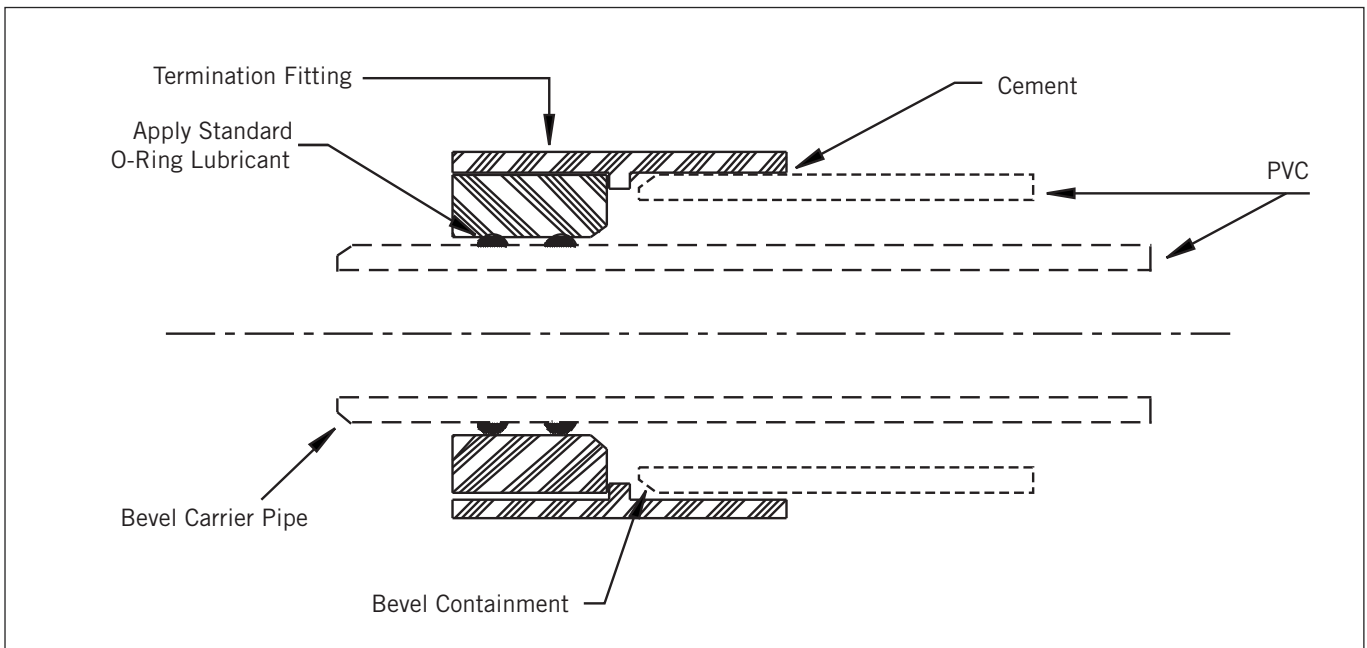

## Closure Couplings

### PVC Notes

Guardian closure coupling installations 3" and up requires the following:

- 1 litre containers of Eco-cleaner and PVC one-step cement
- 3" brushes

**IMPORTANT: Always apply Eco-cleaner and cement liberally. Do not take shortcuts. Follow Guardian instructions explicitly.**

**Note:** Always allow 48 hours or more, depending on environmental conditions, to cure before testing carrier/containment pipe.

### Common Mistakes

- Insufficient amount of cement
- Incorrect or outdated cement
- Eco-cleaner not being used
- Pipe ends not chamfered
- Pipes misaligned
- Contamination (dirt) on cementing area
- Improper positioning of closure coupling on containment pipe
- Movement of pipe sections before cement is fully cured
- Wrong size brush



## System Design

1. Always use containment pipe dimensions as the basis for determining piping layout, centre-to-centre dimensions and expansion loop size.
2. Termination fittings are usually required at the beginning, end and at any branch line of double containment systems, except when draining back to a collection sump, pit or tank.
3. Systems with long runs or extreme temperature changes may require expansion loops or elbows.
4. Complete information regarding media should always be provided to Durapipe UK prior to installation to determine proper piping material and elastomer seals.
5. For above-ground and outdoor applications, UV protection may be required on certain materials. Care should be taken to avoid exposure to UV light, eg. sunlight, particularly during storage. This will cause discoloration and deterioration of the PVC-U material. Whilst this is a surface effect only, it is recommended that precautions be taken to prevent this happening. If stored outdoors pipe should be covered with opaque sheeting. If installed outdoors it can be protected from the effects of UV by insulating or painting.

### Standard Sizes

1/2" # 2"
3/4" # 3"
1" # 3"
2" # 4"
3" # 6"
4" # 8"
6" # 10"
8" # 12"

Care should be taken to avoid exposure to UV light, eg. sunlight, particularly during storage. This will cause discoloration and deterioration of the PVC-U material. Whilst this is a surface effect only, it is recommended that precautions be taken to prevent this happening. If stored outdoors pipe should be covered with opaque sheeting. If installed outdoors it can be protected from the effects of UV by insulating or painting.

## External Support

Additional external support considerations should be given to components such as valves, in-line pumps or other heavy items.

Horizontal piping systems should be supported on uniform centers, which are determined by maximum containment pipe temperatures (see support chart for recommendations). Values apply to uninsulated lines either in a building or exposed to the environment.

Regardless of the type of hanger selected, it is important to note that a wide surface is recommended, free from burrs and sharp edges. Do not anchor by means of a U-bolt directly to the containment pipe.

### Recommended support spacing (m)

Size	Temperature °C				
	20	30	40	50	60
1"#3"	3.20	3.20	2.74	1.83	1.68
2"#4"	3.41	3.20	2.96	2.04	1.83
3"#6"	3.87	3.66	3.41	2.29	2.04
4"#8"	4.11	3.87	3.66	2.29	2.04

## Expansion Loop and Elbows

A common method to control the effects of expansion or contraction in a piping system is to install a combination of anchors and guides with expansion loops. Anchors direct pipe to free movement area. Guides control the carrier pipe movement down the bore of the containment pipe to, and away from, the expansion loop. A relaxed expansion loop as well as one subjected to temperature change are depicted below. As you can see, when a pipe is subjected to temperature change, some degree of movement will occur. Failure to compensate for temperature change may cause stress and ultimately failure.

The carrier and containment pipes are anchored together at every change of direction due to the way in which the unique Centra-Lok™ component connects the fittings together. For this reason it is important to install standard tees (outer) and 90° elbows (inner) in order to allow for the carrier pipe to move independently. The open socket can then be plugged once the system has been pressure tested. See pages 11-13 for details on calculating expansion loop size.

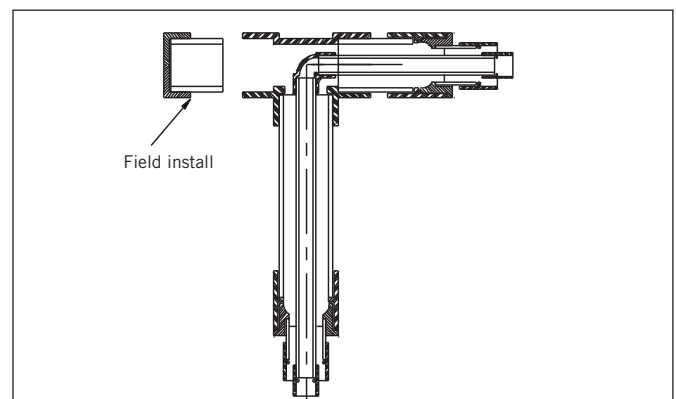
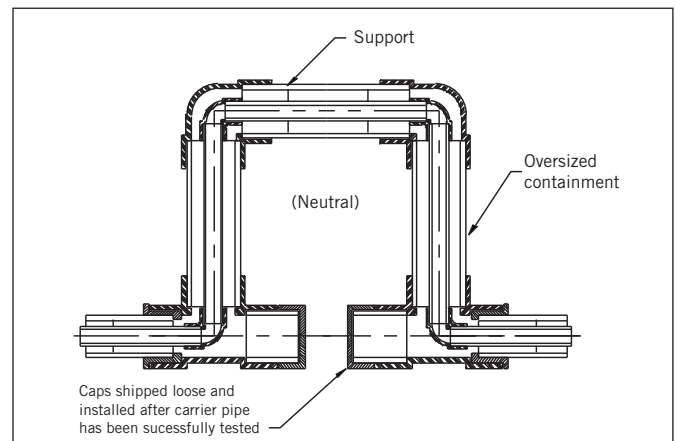
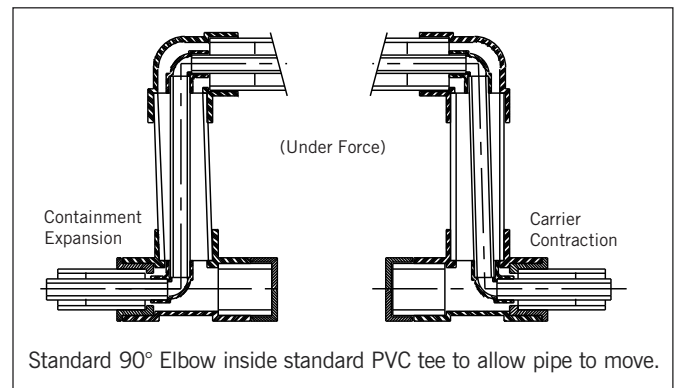

## Guardian Dimensional Information

### PVC Pipe class E/C pipe

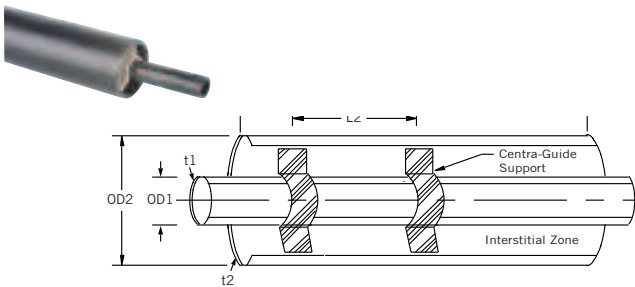

Carrier/ Containment	Class	L <sub>1</sub> m	L <sub>2</sub> m	OD1 mm	t <sub>1</sub> mm	OD2	t <sub>2</sub> mm	Code
1/2"#2"	E/C	6	1.5	21.2	1.9	60.2	3.4	08 513 102
3/4"#3"	E/C	6	1.5	26.6	2.4	88.7	5.0	08 513 103
1"#3"	E/C	6	1.5	33.4	3.0	88.7	5.0	08 513 104
1 1/2"#4"	E/C	6	1.5	48.1	4.4	114.1	6.4	08 513 106
2"#4"	E/C	6	1.5	60.2	5.4	114.1	6.4	08 513 107
3"#6"	E/C	6	1.5	88.7	8.1	168.0	9.4	08 513 109
4"#8"	E/C	6	1.5	114.1	10.3	218.8	12.2	08 513 110
6"#10"	E/C	TBA	TBA	TBA	TBA	TBA	TBA	08 513 112
8"#12"	D/C	TBA	TBA	TBA	TBA	TBA	TBA	08 512 113

Carrier pipe is Class E or Class D. Containment pipe is Class C.

### Centra-Lok™ 90° Tees Equal plain

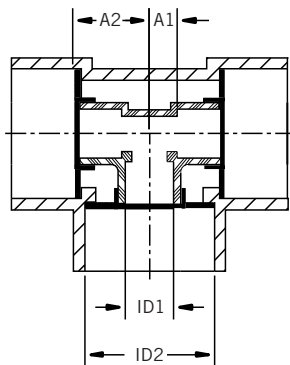

Carrier/ Containment	A1	A2	ID1	ID2	Code
1/2"#2"	12.7	35.1	21.3	60.5	08 122 102
3/4"#3"	17.3	49.8	26.7	88.9	08 122 103
1"#3"	19.1	49.8	33.5	88.9	08 122 104
1 1/2"#4"	26.9	65.8	48.3	114.3	08 122 106
2"#4"	31.8	65.8	60.5	114.3	08 122 107
3"#6"	46.7	95.0	88.9	168.1	08 122 109
4"#8"	59.4	122.2	114.3	218.9	08 122 110
6"#10"	155.4	238.3	168.1	273.1	08 122 112
8"#12"	180.8	301.5	218.9	323.9	08 122 113

### Centra-Lok™ 90° Elbows Plain

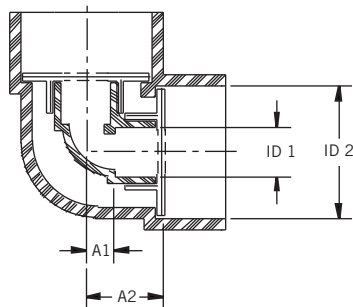

Carrier/ Containment	A1	A2	ID1	ID2	Code
1/2"#2"	12.7	35.1	21.3	60.5	08 115 102
3/4"#3"	17.3	49.8	26.7	88.9	08 115 103
1"#3"	19.1	49.8	33.5	88.9	08 115 104
1 1/2"#4"	26.9	65.8	48.3	114.3	08 115 106
2"#4"	31.8	65.8	60.5	114.3	08 115 107
3"#6"	46.7	95.0	88.9	168.1	08 115 109
4"#8"	59.4	122.2	114.3	218.9	08 115 110
6"#10"	88.9	150.6	168.1	273.1	08 115 112
8"#12"	115.8	176.0	218.9	323.9	08 115 113

**CAUTION:** Do not use or test the products in this manual with compressed air or other gases.

## Centra-Lok™ 45° Elbows Plain

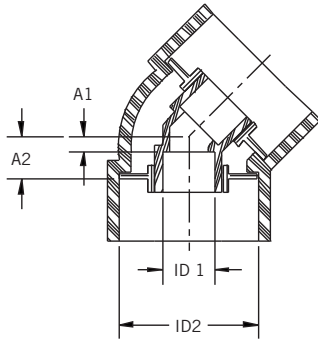

Carrier/Containment	A1	A2	ID1	ID2	Code
1/2"#2"	6.4	22.1	21.3	60.5	08 119 102
3/4"#3"	8.6	25.4	26.7	88.9	08 119 103
1"#3"	9.7	25.4	33.5	88.9	08 119 104
1 1/2"#4"	12.7	31.8	48.3	114.3	08 119 106
2"#4"	15.7	31.8	60.5	114.3	08 119 107
3"#6"	19.1	50.8	88.9	168.1	08 119 109
4"#8"	25.4	57.2	114.3	218.9	08 119 110
6"#10"	44.5	120.7	168.1	273.1	08 119 112
8"#12"	50.8	173.0	218.9	323.9	08 119 113

## PVC/PVC Termination fitting EPDM Plain/O-Ring seal

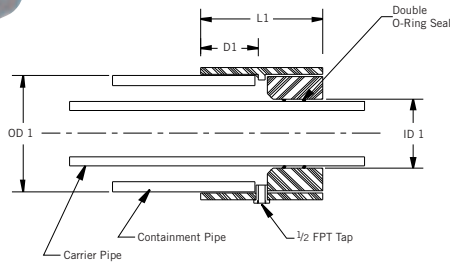

Carrier/Containment	L1	D1	ID1	OD1	Code
1/2"#2"	61.2	38.1	21.3	60.5	08 143 102
3/4"#3"	100.8	47.8	26.7	88.9	08 143 103
1"#3"	100.8	47.8	33.5	88.9	08 143 104
1 1/2"#4"	119.1	57.2	48.3	114.3	08 143 106
2"#4"	119.1	57.2	60.2	114.3	08 143 107
3"#6"	158.8	76.2	88.9	168.4	08 143 109
4"#8"	215.9	101.6	114.3	219.2	08 143 110

## PVC/PVC Termination fitting FPM Plain/O-Ring seal

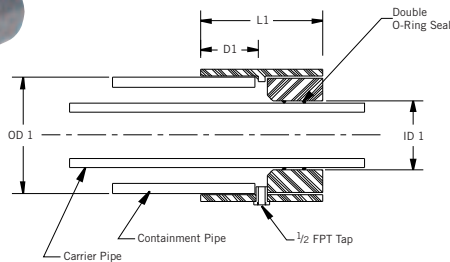

Carrier/Containment	L1	D1	ID1	OD1	Code
1/2"#2"	61.2	38.1	21.3	60.5	08 144 102
3/4"#3"	100.8	47.8	26.7	88.9	08 144 103
1"#3"	100.8	47.8	33.5	88.9	08 144 104
1 1/2"#4"	119.1	57.2	48.3	114.3	08 144 106
2"#4"	119.1	57.2	60.2	114.3	08 144 107
3"#6"	158.8	76.2	88.9	168.4	08 144 109
4"#8"	215.9	101.6	114.3	219.2	08 144 110

## PVC/PVC VKD valve Plain

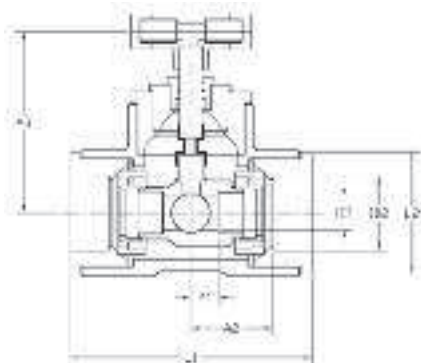

Carrier/Containment	L1	L2	A3	ID1	ID2	Code
1/2"#2"	192	104	186	21.3	60.5	08 DKE 102
3/4"#3"	196	106	213	26.7	88.9	08 DKE 103
1"#3"	260	135	242	33.5	88.9	08 DKE 104
1 1/2"#4"	310	200	269	48.3	114.3	08 DKE 106
2"#4"	370	200	299	60.5	114.3	08 DKE 107
3"#6"	460	270	370	88.9	168.1	08 DKE 109
4"#8"	620	310	480	114.3	218.9	08 DKE 110

**CAUTION:** Do not use or test the products in this manual with compressed air or other gases.



## Guardian Leak Detection Kits

**Standard leak detection kit** Consisting of equal tee, bush, 1m clear PVC pipe and VXE Easyfit PVC ball valve

Description	Code
Leak detection tee kit to fit 2" OD containment pipe	08 191 107
Leak detection tee kit to fit 3" OD containment pipe	08 191 109
Leak detection tee kit to fit 4" OD containment pipe	08 191 110
Leak detection tee kit to fit 6" OD containment pipe	08 191 112
Leak detection tee kit to fit 8" OD containment pipe	08 191 113

**Retrofit leak detection kit** Consisting of clamp saddle, threaded socket, threaded adaptor, 1m clear PVC pipe and VXE Easyfit PVC ball valve

Description	Code
Leak detection saddle kit to fit 2" OD containment pipe	08 192 107
Leak detection saddle kit to fit 3" OD containment pipe	08 192 109
Leak detection saddle kit to fit 4" OD containment pipe	08 192 110
Leak detection saddle kit to fit 6" OD containment pipe	08 192 112
Leak detection saddle kit to fit 8" OD containment pipe	08 192 113



## Durapipe Leak Detection System – By Andel Limited

Durapipe recommend a leak detection system from Andel Limited. Andel Limited was formed in 1992 and with a commitment to service, product development and quality, has a proven track record as the market leader in leak detection systems.

The sensor uses infrared to detect the presence of any liquid touching the sensor dome. When liquid is detected, the relay within the local control unit will turn off, and therefore be detected by a monitoring system. The relay will also turn off if the sensor should become disconnected or if the power should fail.

The Andel Pipe-in-Pipe leak detection system is designed for applications where a stand-alone leak detection system is required. The system consists of two components, the sensor head and local control box. The sensor head is a 1" BSP fitting and can be installed onto a standard leak detection kit using a standard threaded branch tee.

The sensor head is designed using an optical level sensor. The sensor head will be encapsulated and fit into a standard 1" BSPT female socket and comes complete with 2m of connection cable. The ingress protection of the unit is IP65.

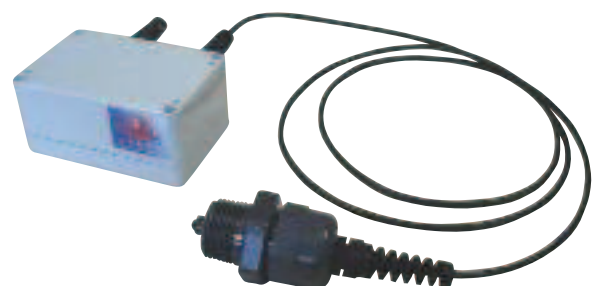

## Durapipe UK Pipework Systems



### ABS

- Ideal for chilled, potable and waste water
- Tough, durable, lightweight and fully approved
- Suitable for use from -40°C to +70°C
- Fully matched system of pipes, fittings and valves



### DURACOOL

- Lightweight
- Easy to install
- Cost-efficient installation
- Wide temperature range
- Tough and durable

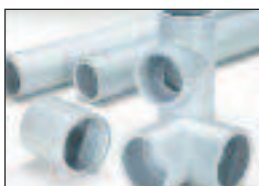

### Air-Line Xtra

- High performance thermoplastic pipework system for compressed air



### Corzan

- Solvent weld thermoplastic pipe system for aggressive substances
- Designed specifically for use in highly corrosive conditions at temperatures up to 95°C
- Valves range available



### Flow Control

- Manual and actuated flow control solutions
- For use with all Durapipe systems
- Lightweight and easy to install



### PLX

- Purpose designed for safe fuel transfer
- Suitable for pressure and vacuum applications
- Resists fuel permeation



### Polypropylene

- Conveys chemicals at temperatures up to 100°C
- Excellent resistance to a wide range of substances
- Available in larger diameters up to 500mm
- Full range of valves

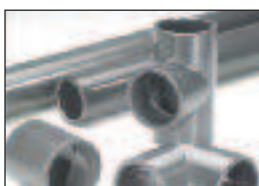

### PVC-U

- Versatile, multi-purpose solvent weld pipework system with an extensive range of valves and fittings
- The established system for process and industrial handling of chemicals and water up to 60°C
- Guardian dual contained PVC-U pipework system



### Vulcathene

- Safe chemical drainage
- Two easy jointing methods - Mechanical or Enfusion
- Ideal for schools, universities and colleges, hospitals and clinics, pharmaceutical and research organisations

## DURAPIPE UK CONDITIONS OF SALE

1. **DEFINITIONS:**  
‘Seller’ shall mean Glynwed Pipe Systems Limited, registered in England under number 1698059. ‘Buyer’ shall mean any company, organisation or individual to whom a quotation is offered, or whose order is accepted by the Seller.
2. **CONDITIONS:**  
All offers, quotations, estimates, acceptances and contracts are subject to these Conditions of Business and any terms or conditions which any other person shall seek to impose or make part of any contract shall, so far as is inconsistent with these Conditions of Business, not apply unless expressly agreed by the Seller in writing. The headings in these conditions are for convenience only and shall not affect their interpretation.
3. **QUOTATIONS AND PRICE VARIATION:**
  - a) Any quotation given by the Seller is an invitation to the Buyer to make an offer only and no order of the Buyer placed with the Seller in pursuance of a quotation or otherwise shall be binding on the Seller unless and until it is accepted in writing by the Seller.
  - b) Unless stated otherwise, all quotations and published price lists are ex works, exclusive of VAT and shall remain valid for 30 days or such a period as may be quoted but nevertheless the Seller may amend or withdraw any quotation by written or oral notice. Quotations may be varied if the Buyer makes variations in his specifications.
4. **STATEMENTS OR REPRESENTATIONS TO THE BUYER:**  
If any statement or representation has been made to the Buyer upon which the Buyer relies other than in the documents enclosed with the Seller’s quotation, the Buyer must set out that statement or representation in a document to be attached to or endorsed on the order in which case the Seller may submit a new quotation.
5. **DELIVERY - TIME:**
  - a) Any period for delivery given at any time and in any manner by the Seller is an estimate only and is not binding on the Seller. Delivery periods are normally calculated from the later of:
    - i) acceptance of order; or
    - ii) where applicable, the receipt by the Seller of a detailed specification or drawings.
  - b) Time shall not be deemed to be of the essence of the contract. Failure by the Seller to meet any quoted delivery period for any part or the whole of the order shall not entitle the Buyer to rescind the contract or to claim damages of any nature.
  - c) The Seller will endeavour to comply with reasonable requests by the Buyer for postponement of delivery but shall be under no obligation to do so. Where delivery is postponed otherwise than due to default by the Seller the Buyer shall pay all costs and expenses including a reasonable charge for storage and transportation occasioned thereby and an extra charge for split delivery if applicable.
  - d) The Buyer will receive delivery of any consignment between the hours of 8.00am and 4.00pm Monday to Friday inclusive, unless otherwise agreed in writing. Cost incurred by the Seller arising from the Buyer’s refusal to accept consignments within the agreed hours shall be borne by the Buyer.
6. **DELIVERY AND RISK:**
  - a) Except where stated to the contrary in the contract, delivery shall be made as follows:
    - i) where the Buyer provides the transport, delivery shall be made ex the Seller’s works;
    - ii) where the Seller provides the transport, delivery shall be made to the premises of the Buyer, or the premises of the Buyer’s customer or works site if the Buyer has requested delivery to be so made but where the Buyer has made such a request the Seller will make a first delivery to the Buyer’s customer or works site as so much of the goods as is available for that delivery but subsequent deliveries will be made to the premises of the Buyer.
  - b) The Seller may at its discretion make partial delivery of orders and invoice the same.
  - c) Risk in the goods shall pass on delivery.
  - d) Where goods are sent FOB the Seller’s responsibility shall cease when the goods are placed on board ship or aircraft without the need for the Seller to give notice to the Buyer and the provisions of Section 32(3) of the Sale of Goods Act 1979 shall not apply.
7. **OWNERSHIP OF GOODS:**
  - a) The goods shall remain the sole and absolute property of the Seller as legal and equitable owner until such time as the Buyer shall have paid to the Seller the contract price together with the full price of any other goods the subject of any contract between the Seller and the Buyer.
  - b) The Buyer acknowledges that until such time as the property in the goods passes to the Buyer he is in possession of the goods as a bailee and fiduciary agent for the Seller and the Purchaser shall store the goods in such a manner that they are clearly identifiable as the property of the Seller.
  - c) Until payment due under all contracts between the Buyer and the Seller had been made in full, in the event of sale of the goods by the Buyer:
    - i) the Seller shall be entitled to trace all proceeds of sale received by the Buyer through any bank or other account maintained by the Buyer; and
    - ii) the Buyer shall if requested by the Seller in writing to so assign its rights to recover the selling price of the goods from the third parties concerned. Such monies to be held separately by the Buyer as agent on behalf of the Seller.
  - d) The Seller may for the purpose of recovery of its goods enter upon any premises where they are stored or where they are reasonably thought to be stored and may repossess the same.
8. **TERMS OF PAYMENT:**  
In the event of default in payment according to the agreed payment terms between the Seller and the Buyer – ie: by the end of the month following the month of despatch of the goods the Seller shall be entitled without prejudice to any other right or remedy to suspend all further deliveries and to charge interest on any amount outstanding at the rate of 2% per month until payment in full is made (a part of a month being treated as a full month for the purpose of calculating interest).
9. **SHORTAGES AND DEFECTS APPARENT ON DELIVERY:**
  - a) It shall be the responsibility of the Buyer to inspect or arrange for an inspection of the goods on delivery whether the goods are delivered to the Buyer’s premises or to the premises of the Buyer’s customer or to a works site. If no such inspection is made the Buyer shall be deemed to have accepted the goods.
  - b) The Buyer shall have no claim for shortages or defects apparent on inspection unless:
    - i) a written complaint is made to the Seller within three days of receipt of the goods specifying the shortage or defect; and
    - ii) the Seller is within seven days of receipt of the complaint given an opportunity to inspect the goods and investigate the complaint before any use is made of the goods.
  - c) If a complaint is not made to the Seller as herein provided then in respect of such shortages or defects the goods shall be deemed to be in all respects in accordance with the contract and the Buyer shall be bound to pay for the same accordingly.
10. **CLAIMS FOR DEFECTS NOT APPARENT ON INSPECTION:**
  - a) The Buyer shall have no claim for defects not apparent on inspection unless the Seller is notified of defective workmanship or materials within twelve months from delivery of the goods. Provided that the goods have been installed and applied in accordance with any relevant recommendations made by the Seller, the Seller will at its option replace the goods or refund the net invoiced price in respect of the goods which have been shown to be defective. If the Seller does so supply substitute goods the Buyer shall be bound to accept such substituted goods in full satisfaction of the obligations of the Seller under the contract.
  - b) The Buyer shall in any event have no claim or set-off in respect of defects unless a written complaint is sent to the Seller as soon as the defect is noticed and no use is made of the goods thereafter or alteration made thereto by the Buyer before the Seller is given an opportunity to inspect the goods.
  - c) The Buyer is responsible for ensuring that the goods are fit for any particular purpose, and no warranty or condition of fitness for any particular purpose is to be implied into the contract.
11. **LIABILITY:**  
Save as stated in Conditions 9 and 10 (and save in respect of death or personal injury resulting from the negligence of the Seller its servants or agents) the Seller shall not be liable for any claim or claims for direct or indirect consequential or incidental injury loss or damage made by the Buyer against the Seller whether in contract or in tort (including negligence on the part of the Seller its servants or agents) arising out of or in connection with any defect in the goods or their fitness or otherwise for any particular purpose or any act omission neglect or default of the Seller its servants or agents in the performance of the contract.
12. **FORCE MAJEURE:**  
Notwithstanding anything herein contained neither the Buyer nor the Seller is to be held liable for any delay or failure to carry out the contract due wholly or in part to an act of God action by any Government whether British or foreign civil war strikes and/or lockouts wheresoever occurring fire trade disputes floods or unfavourable weather or any material becoming unavailable or irreplaceable (whether at all or at commercially acceptable prices) or any other circumstances beyond the control of the Seller.
13. **SUB-CONTRACTING:**  
The Seller reserves the right to sub-contract the fulfilment of any order or any part thereof.
14. **INSOLVENCY AND BREACH OF CONTRACT:**  
In the event that:
  - a) the Buyer commits any breach of the contract and fails to remedy such breach (if capable of remedy) within a period of thirty days from receipt of a notice in writing from the Seller requesting such remedy; or
  - b) any distress or execution is levied upon any of the goods or property of the Buyer; or
  - c) the Buyer offers to make any arrangements with or for the benefit of its creditors or (if an individual) becomes subject to a petition for a bankruptcy order or (being a limited company) has a receiver appointed of the whole or any part of its undertaking property or assets; or
  - d) an order is made or a resolution is passed or analogous proceedings are taken for the winding up of the Buyer (save for the purpose of reconstruction or amalgamation with insolvency and previously approved in writing by the Seller) the Seller shall thereupon be entitled without prejudice to its other rights hereunder forthwith to suspend all further deliveries until the default has been made good or to determine the contract and any unfulfilled part thereof or at the Seller’s option to make partial deliveries. Notwithstanding any such termination the Buyer shall pay to the Seller at the contract rate for all the goods delivered up to and including the date of termination.
15. **INDUSTRIAL PROPERTY RIGHTS:**  
If goods supplied by the Seller to the Buyer’s design or specifications infringe or are alleged to infringe any patent or registered design right or copyright the Buyer will indemnify the Seller against all damages, costs and expenses incurred by the Seller as a result of the infringement or allegation. The Buyer will give the Seller all possible help in meeting any infringement claim brought against the Seller.
16. **BUYER’S ERROR IN ORDERING:**  
In the event the Buyer orders incorrectly the Seller will be under no obligation to the Buyer to rectify or assist in rectifying the error.
17. **LAW AND JURISDICTION:**  
The contract shall be subject in all respects to English Law and to the jurisdiction of the English Courts.

Durapipe UK reserves the right to modify the details in this publication as products and specifications are updated and improved. The content of this publication is for general information only and it is the user's responsibility to determine the suitability of any product for the purpose intended.

For further information on all Durapipe UK products and services contact our Customer Services Department as detailed below.

**Customer Services**

Tel: 01543 273100

Fax: 0800 317875

Durapipe UK is a trade name of Glynwed Pipe Systems Ltd. Company Number 1698059.

*Registered office:*

**Durapipe UK**

Walsall Road

Norton Canes

Cannock

Staffordshire

WS11 9NS

United Kingdom

Tel: +44 (0)1543 279909

Fax: +44 (0)1543 279450

email: [enquiries@durapipe.co.uk](mailto:enquiries@durapipe.co.uk)

web: [www.durapipe.co.uk](http://www.durapipe.co.uk)

**Distributor**

04900033 September 2010